

# SPS-HZ-7 - QA2-60

## SLIDING PANEL MECHANISM - HORIZONTAL

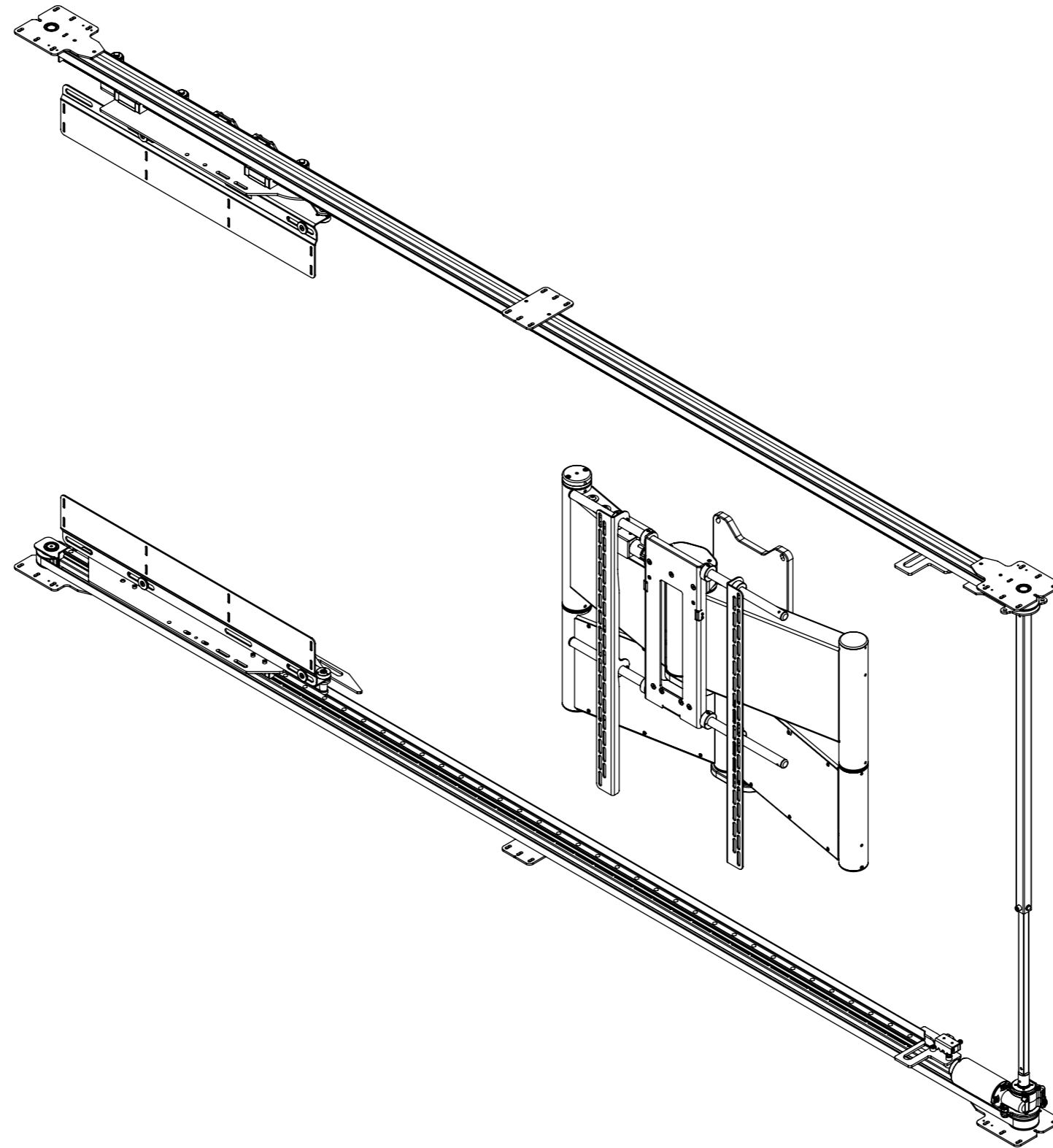

future automation



# SPS-HZ-7 - QA2-60

## SLIDING PANEL MECHANISM - HORIZONTAL

MODEL	DESCRIPTION	MIN SCREEN HEIGHT	MAX SCREEN HEIGHT
SPS-V-5	Vertical - Single Panel	700 [27 9/16"]	800 [31 1/2"]
SPS-V-6	Vertical - Single Panel	801 [31 9/16"]	950 [37 3/8"]
SPS-V-7	Vertical - Single Panel	951 [37 7/16"]	1100[ 43 5/16"]
SPS-V-8	Vertical - Single Panel	1101[ 43 3/8"]	1250[ 49 3/16"]
SPS-VS-5	Vertical - Double Splitting Panel	700 [27 9/16"]	800 [31 1/2"]
SPS-VS-6	Vertical - Double Splitting Panel	801 [31 9/16"]	950 [37 3/8"]
SPS-VS-7	Vertical - Double Splitting Panel	951 [37 7/16"]	1100[ 43 5/16"]
SPS-VS-8	Vertical - Double Splitting Panel	1101[ 43 3/8"]	1250[ 49 3/16"]

MODEL	DESCRIPTION	MIN SCREEN WIDTH	MAX SCREEN WIDTH
SPS-HZ-6	Horizontal - Single Panel	1400 [55 1/8"]	1600 [63"]
<b>SPS-HZ-7</b>	<b>Horizontal - Single Panel</b>	<b>1601 [63 1/16"]</b>	<b>1850 [72 13/16"]</b>
SPS-HZ-8	Horizontal - Single Panel	1851 [72 7/8"]	2100 [82 11/16"]
SPS-HZS-6	Horizontal - Double Splitting Panel	1400 [55 1/8"]	1600 [63"]
SPS-HZS-7	Horizontal - Double Splitting Panel	1601 [63 1/16"]	1850 [72 13/16"]
SPS-HZS-8	Horizontal - Double Splitting Panel	1851 [72 7/8"]	2100 [82 11/16"]

**SPS-V - VERTICAL - SINGLE PANEL**

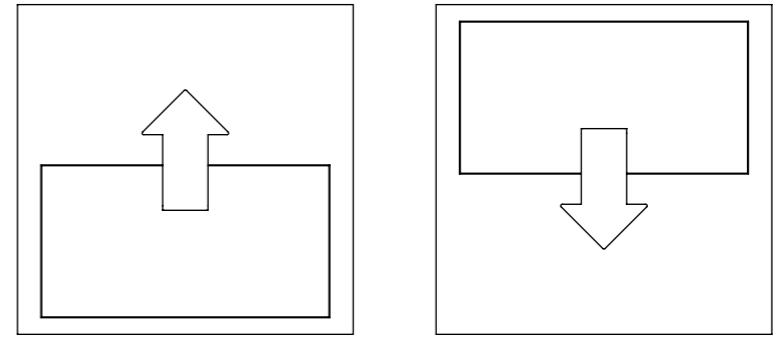

**SPS-VS - VERTICAL SPLIT - DOUBLE PANEL**

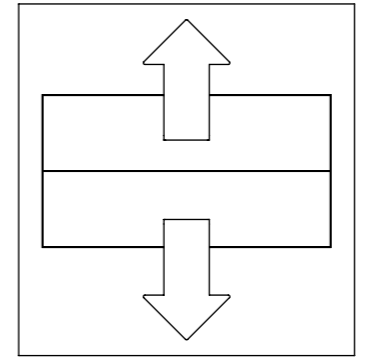

**SPS-HZ - HORIZONTAL - SINGLE PANEL**

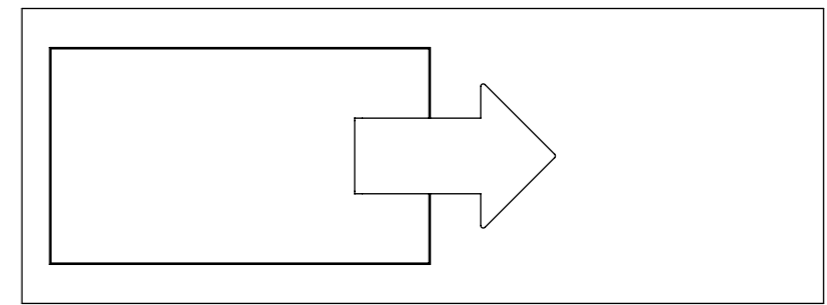

**SPS-HZS - HORIZONTAL SPLIT - DOUBLE PANEL**

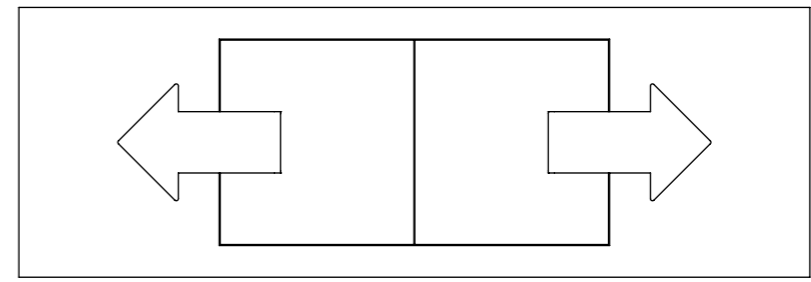

# SPS-HZ-7 - QA2-60

## SLIDING PANEL MECHANISM - HORIZONTAL

SPECIFICATION	MEASUREMENTS
Minimum Screen Width	1601 [63 1/16"]
Maximum Screen Width	1850 [72 13/16"]
Minimum Screen Height	850 [33 7/16"]
Maximum Screen Height	1250 [49 3/16"]
Maximum Moving Panel Weight	15Kg (33lbs)
Maximum Screen Weight	80Kg (176lbs)
Total Mechanism Weight	TBC
Packaging Dimensions (LxWxH)	TBC
Shipping Weight	TBC
Movement Type	Motorised
Power Supply Required	110V - 240V AC
Power Consumption Max.	120W
Power Consumption Standby	3W
Mounting Patterns Supported	VESA 400, 300, 200 W x 400, 300, 200 H
Control Options	IR Remote, RS232
Product Options / Features	AB pairing option
Package Contents	Mechanism, IR remote control, Bolt Pack
Marine Suitable	Yes (Indoor)

1. Panel Closed

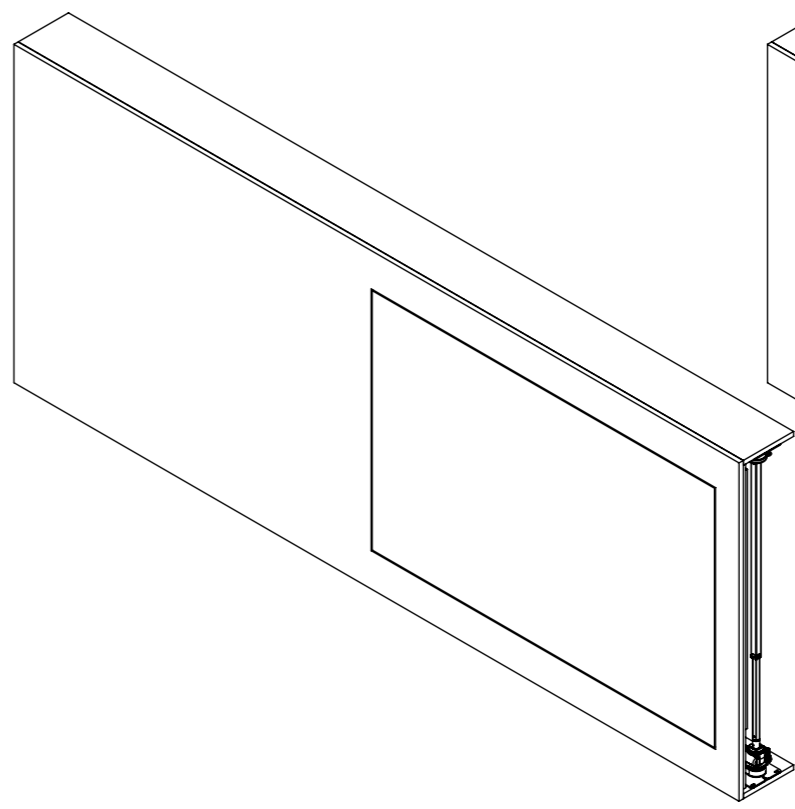

2. Panel Retracts

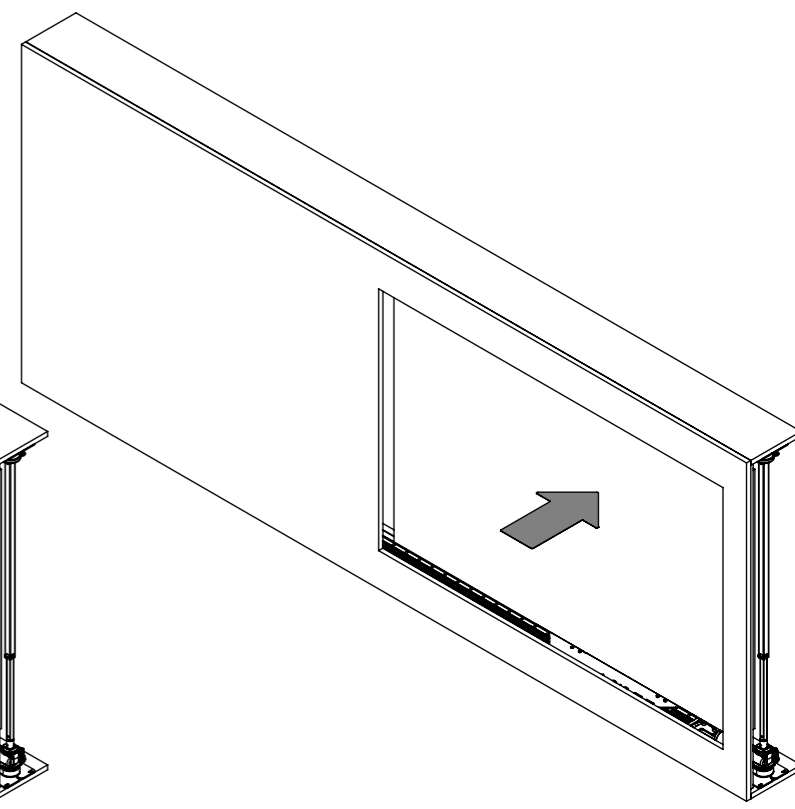

3. Panel Slides

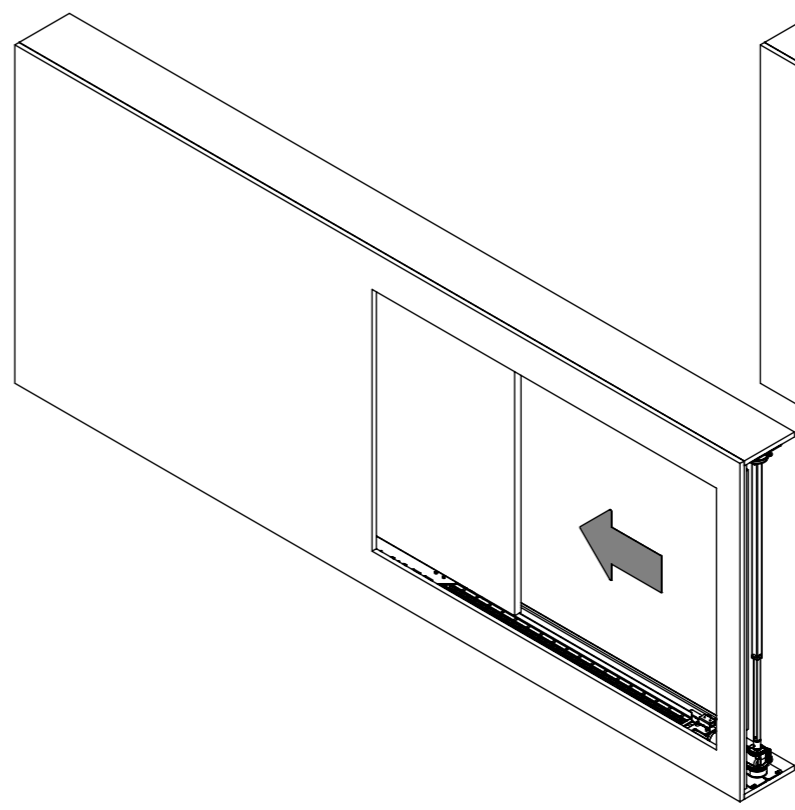

4. Screen Advances

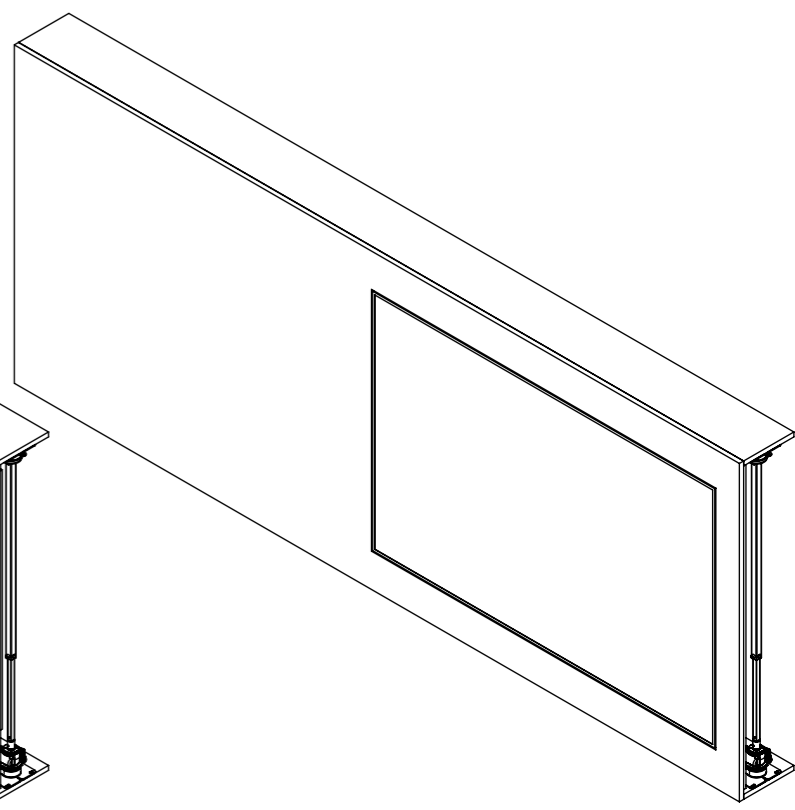

# SPS-HZ-7 - QA2-60

## SLIDING PANEL MECHANISM - HORIZONTAL

### CABINET DIMENSIONS - WIDTH AND HEIGHT

Screen Width	Install Width
1601 [63 1/16"] → 1850 [72 13/16"]	(2 x Screen Width) + 190
Screen Height	Install Height
850 [33 7/16"] → 1250 [49 3/16"]	Screen Height + 280

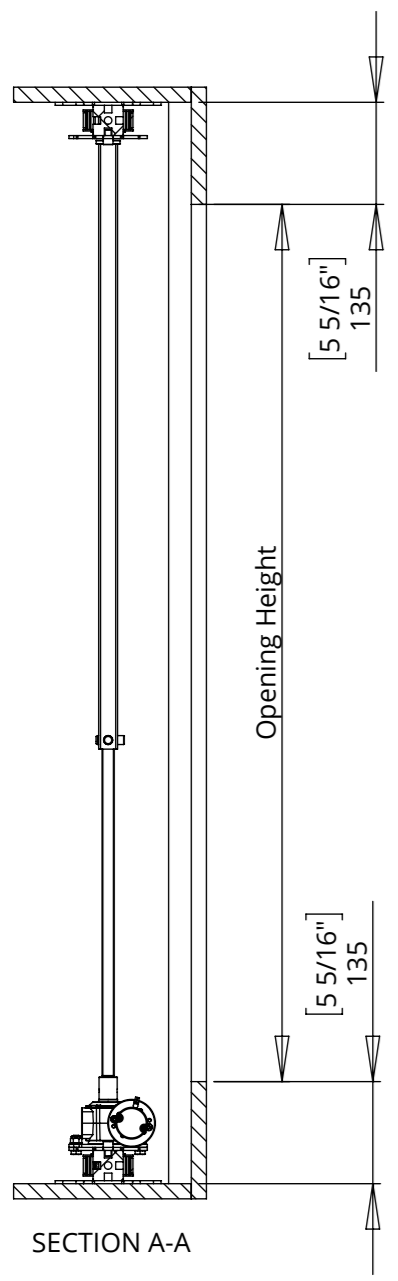
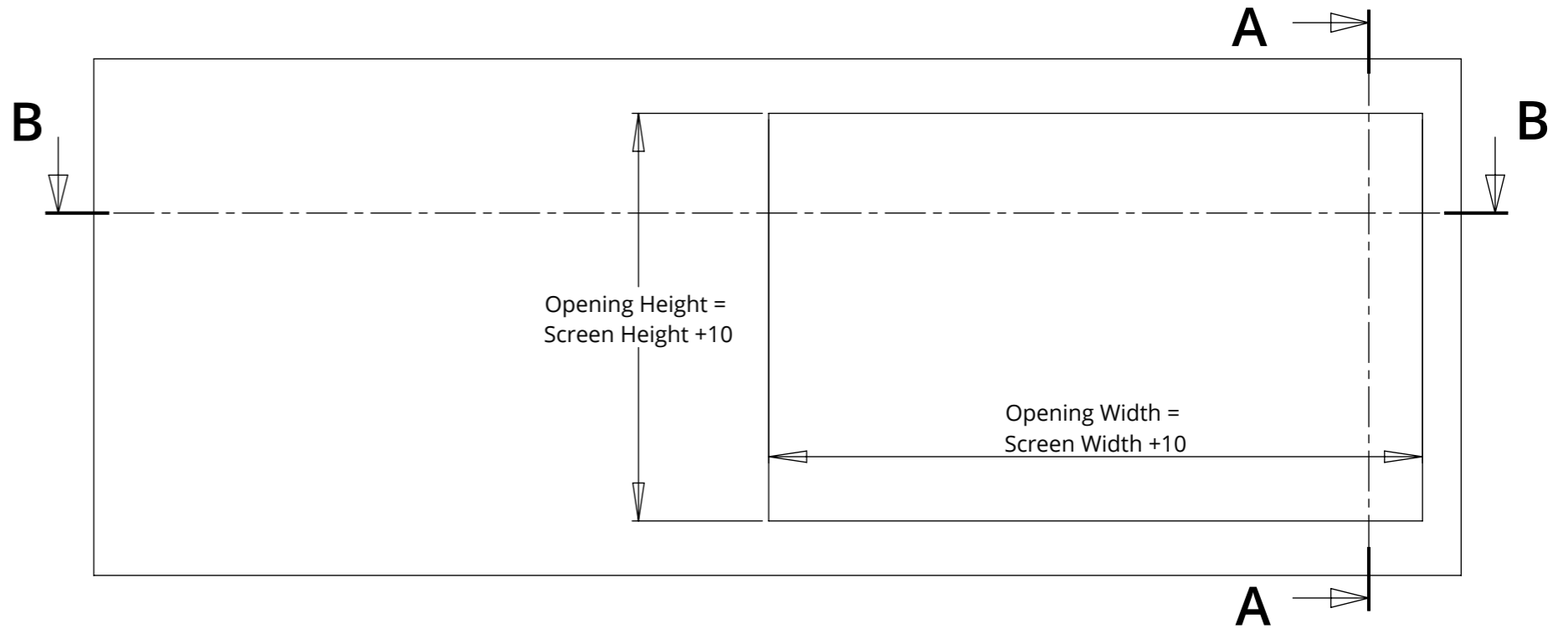

SECTION B-B  
Minimum Screen Height

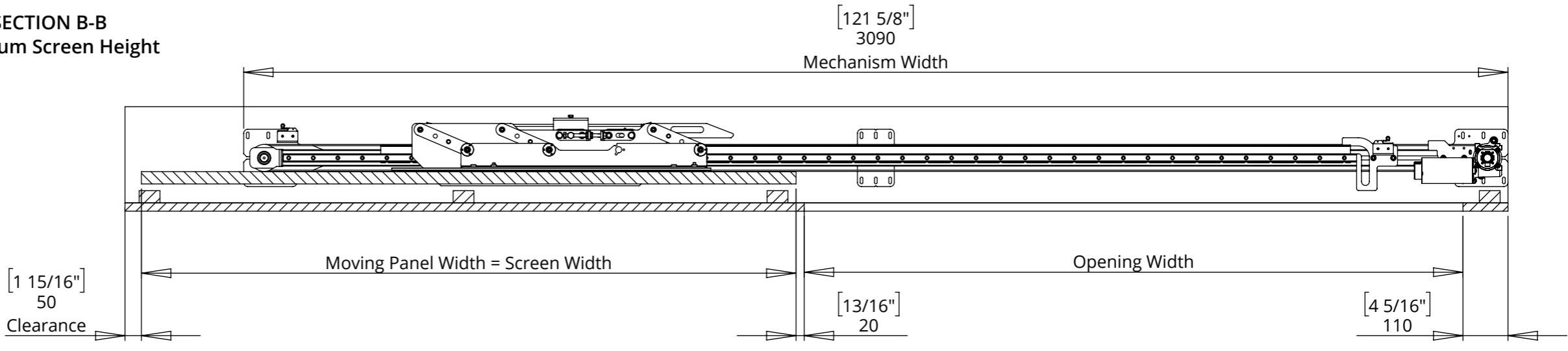

SECTION B-B  
Maximum Screen Height

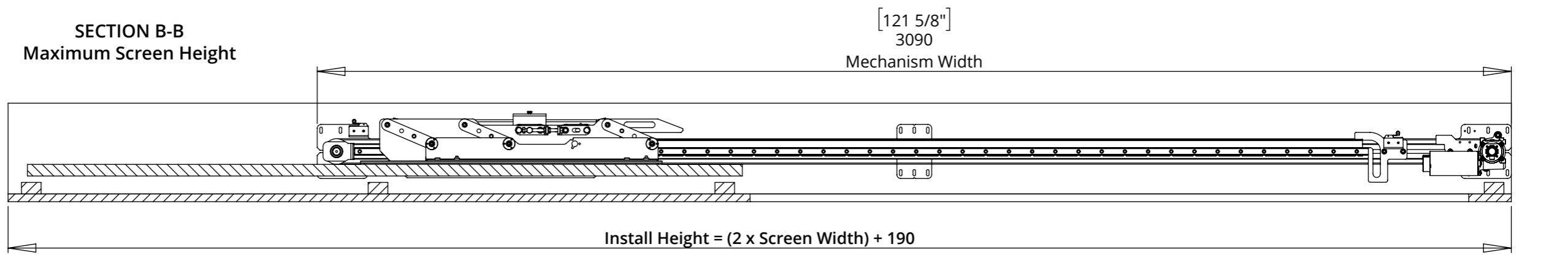

# SPS-HZ-7 - QA2-60

## SLIDING PANEL MECHANISM - HORIZONTAL

### CABINET DIMENSIONS - DEPTH

The minimum depth of 245mm [9 5/8"] allows for a maximum screen depth of 30mm [1 3/16"].

Screens with a greater thickness will need the cabinet depth to increase i.e. a 100mm [3 15/16"] thick screen will require a cabinet of 315mm [12 3/8"].

Screens thinner than 30mm [1 3/16"] must still use the minimum 245mm [9 5/8"] cabinet depth.

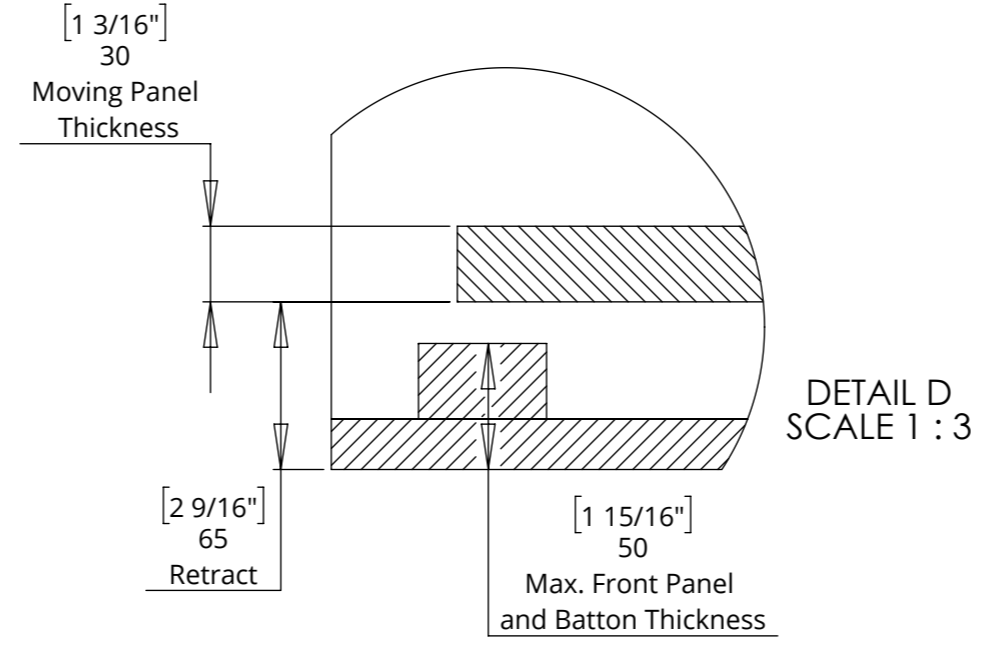

The moving panel retracts back by 65mm [2 9/16"] before Sliding. For this reason it is advised the front panel work and support batten is no more than 50mm [1 15/16"] thick to give 15mm [9/16"] clearance.

Thicker panels are possible, but will add to the cabinet depth and require customisation to the mechanism design.

### Screen - IN

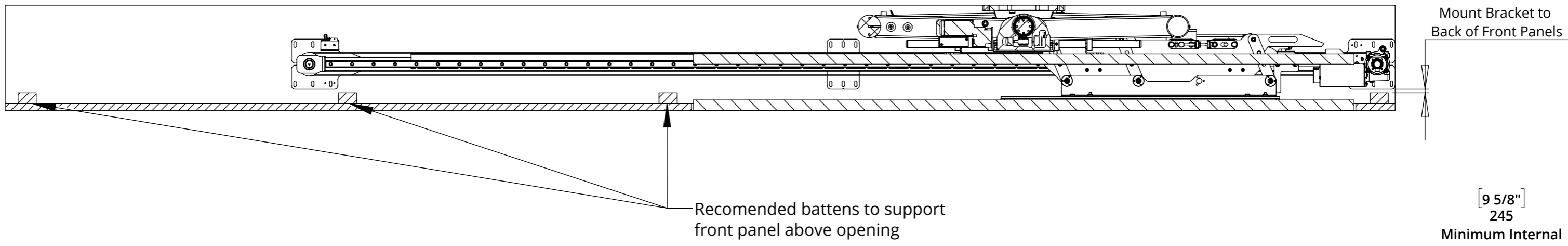

### Screen - OUT

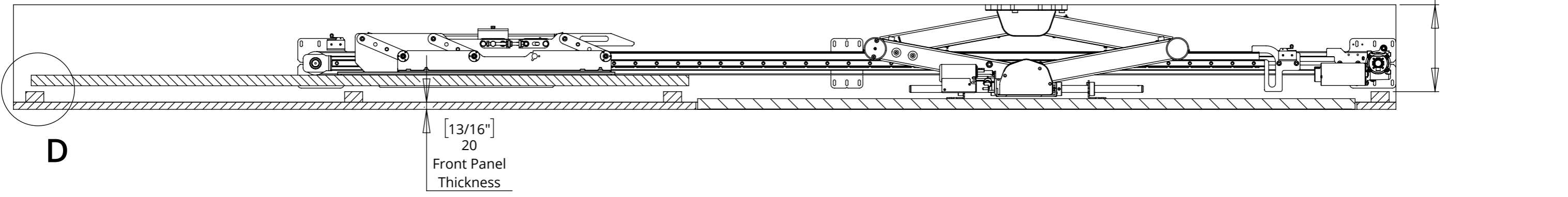

# SPS-HZ-7 - QA2-60

## SLIDING PANEL MECHANISM - HORIZONTAL

### CABINET DETAILS - RIGHT SLIDE

Screen Width	Install Width
1601 [63 1/16"] → 1850 [72 13/16"]	(2 x Screen Width) + 190
Screen Height	Install Height
850 [33 7/16"] → 1250 [49 3/16"]	Screen Height + 280

The SPS-HZ can be inverted so the panel slides right instead. The mechanism used is the same as in the original orientation, the mechanism is just rotated through 180°.

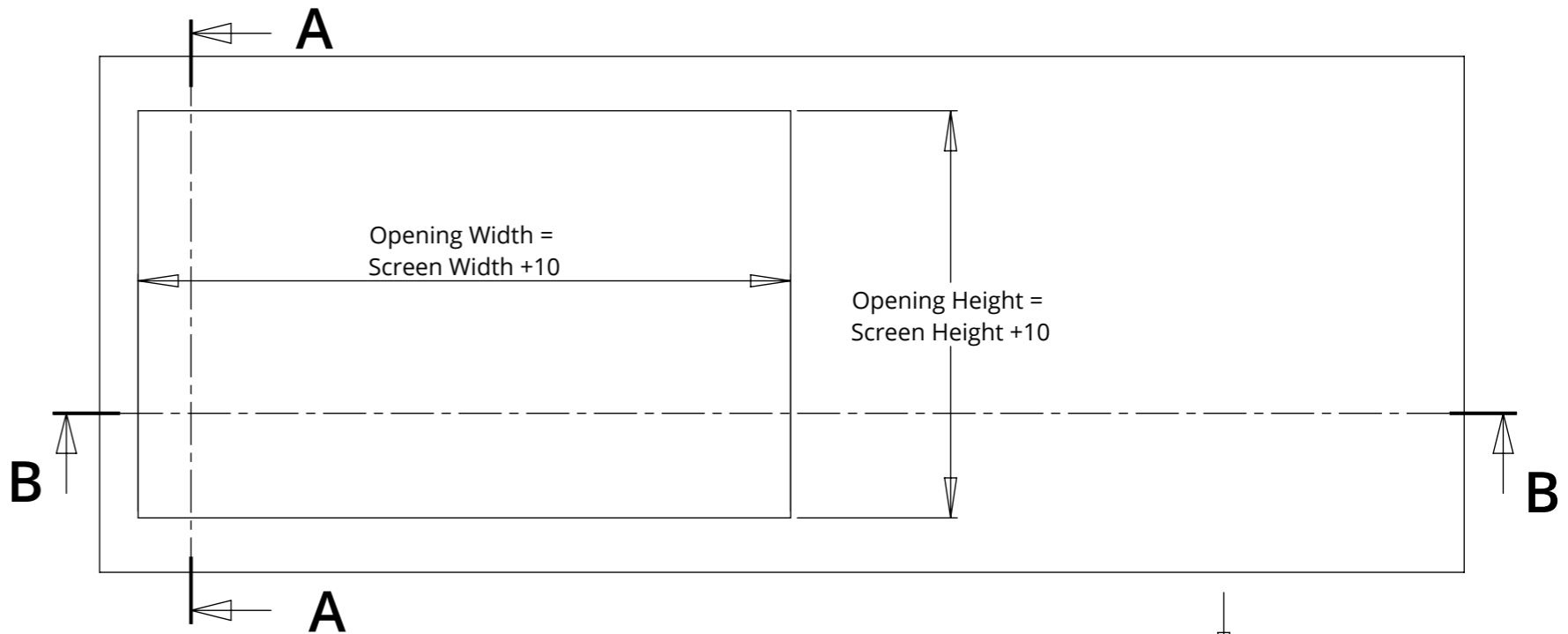

#### 1. Panel Retracts

#### 2. Panel Slides Right

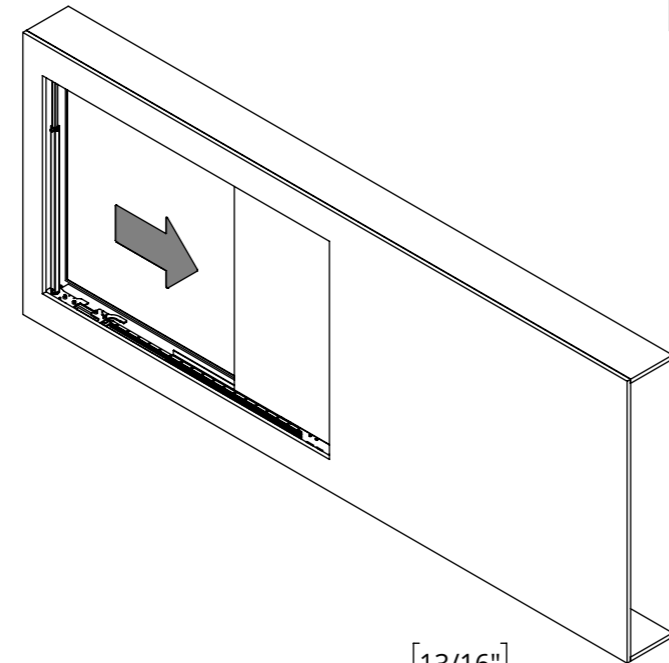
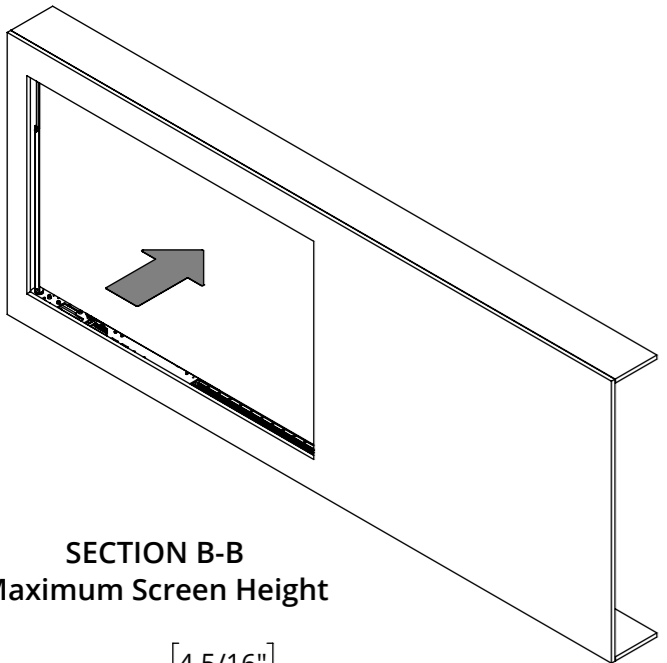

SECTION B-B  
Maximum Screen Height

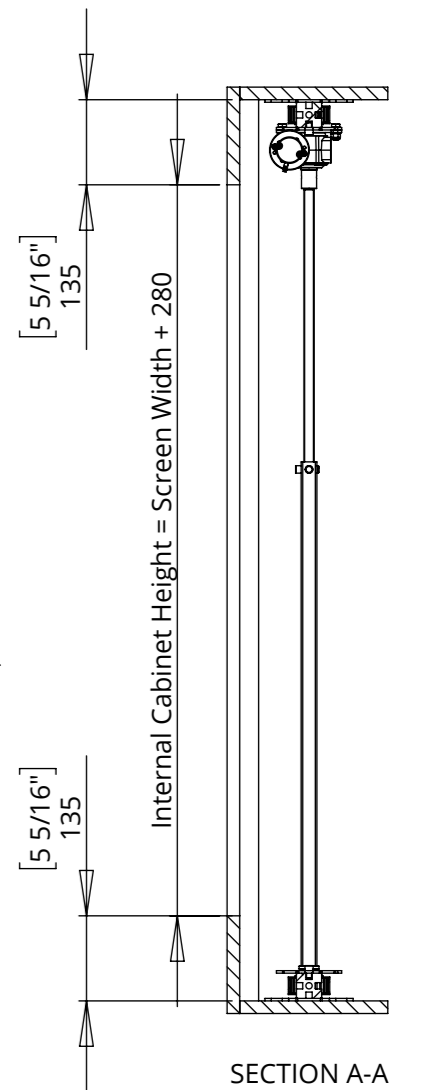
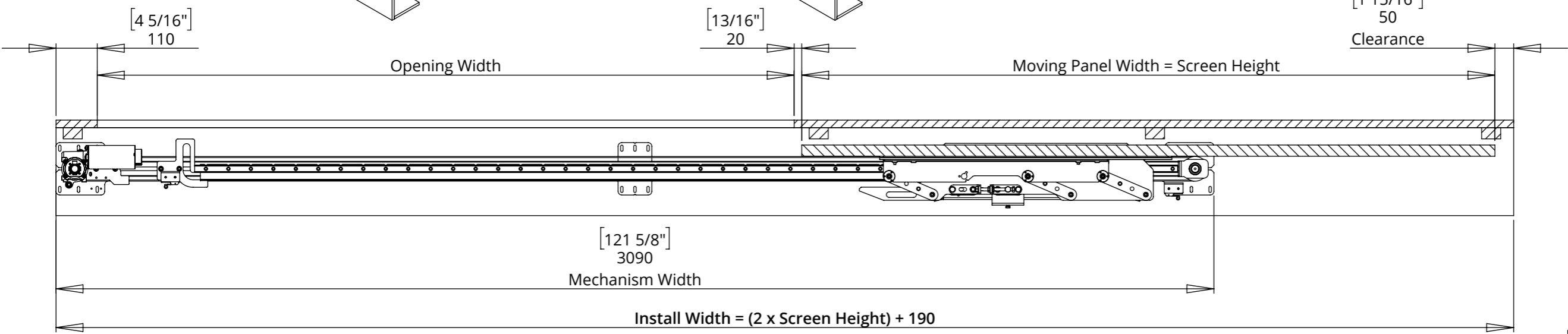

# SPS-HZ-7 - QA2-60

## SLIDING PANEL MECHANISM - HORIZONTAL

### QA2-60 - QUAD ARM

The Quad Arm has a service mode that can be used during installation and servicing of the mechanism and the screen.

This allows the screen to be advanced out from the wall to provide access to rear of the screen and inside the mechanism during fitting.

ADVANCE - IN

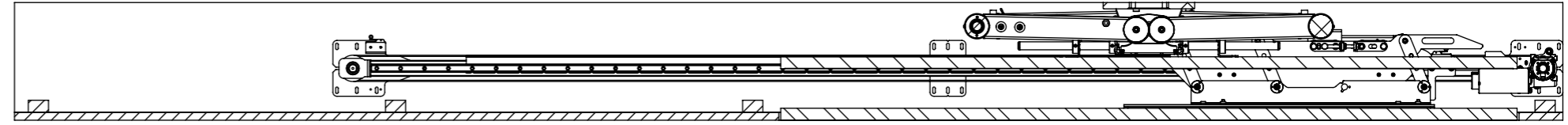

ADVANCE - OUT

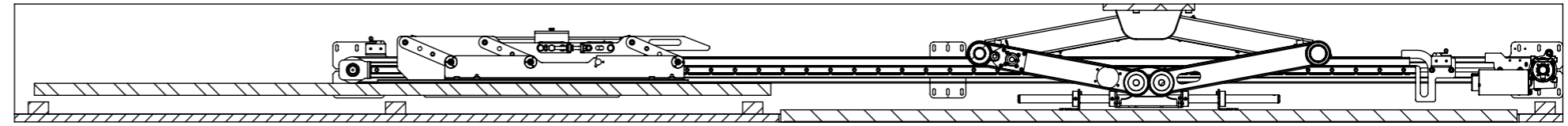

ADVANCE - SERVICE

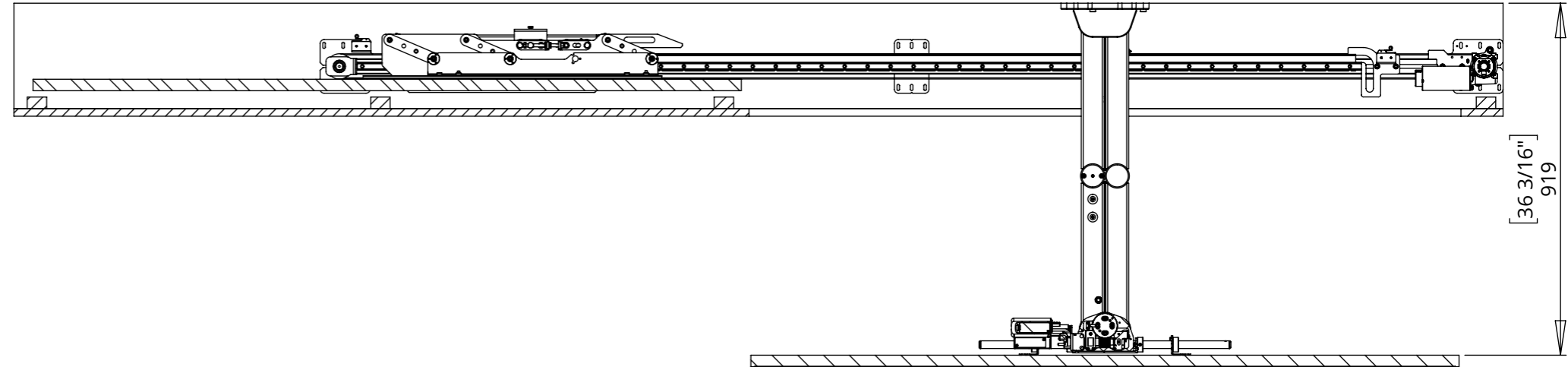

ADVANCE - SERVICE

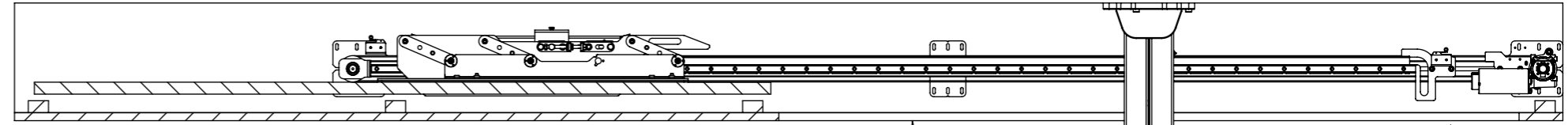

Maximum QA2-60 swivel is 75°. However depending on the screen and cabinet depth this will need to be reduced to prevent the screen being obscured by the cabinet.

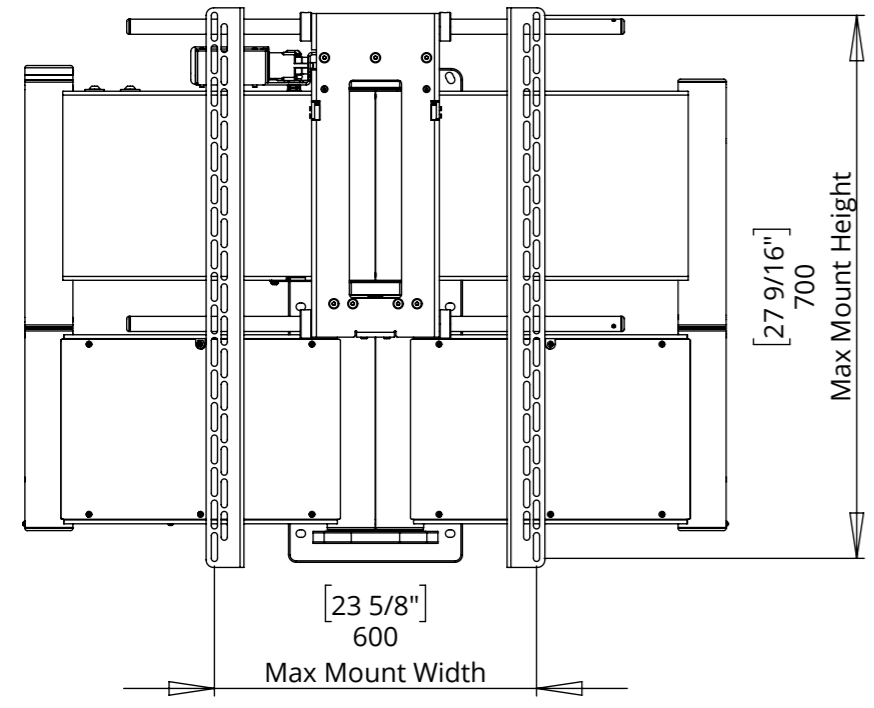
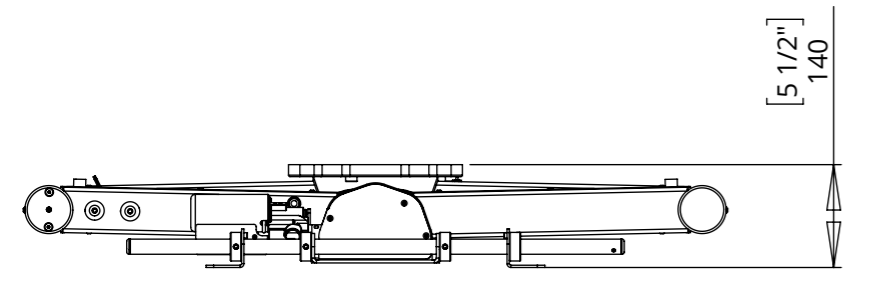

# SPS-HZ-7 - QA2-60

## SLIDING PANEL MECHANISM - HORIZONTAL

### CABINET DETAILING & ACCESS

The SPS mechanism requires certain access for installation and to be serviced.

For installation the side panel must be removable to provide access to all the fixing points of the SPS mechanism.

For servicing the best option is to have the areas to the top and bottom of the opening on hinges. This will provide enough access to everything that will be needed to service and maintain the mechanism. Alternatively these panels could be made to be easily removable on suitable catches / fixings.

The Moving Panel Mechanism mounts to the top and bottom walls of the cabinet, and the Advance Bracket mounts to the back of the cabinet. It is essential that these surfaces can take the weight of the mechanism, moving panel and screen.

The mechanism is supplied with a control box on a 3m [10'] flying lead. This must be fitted in an easily accessible location. This will be the first item to be checked if there is an issue with the mechanism. Mains power and control connections (IR sensor / receiver, contact closure, RS232) are all made at the control box.

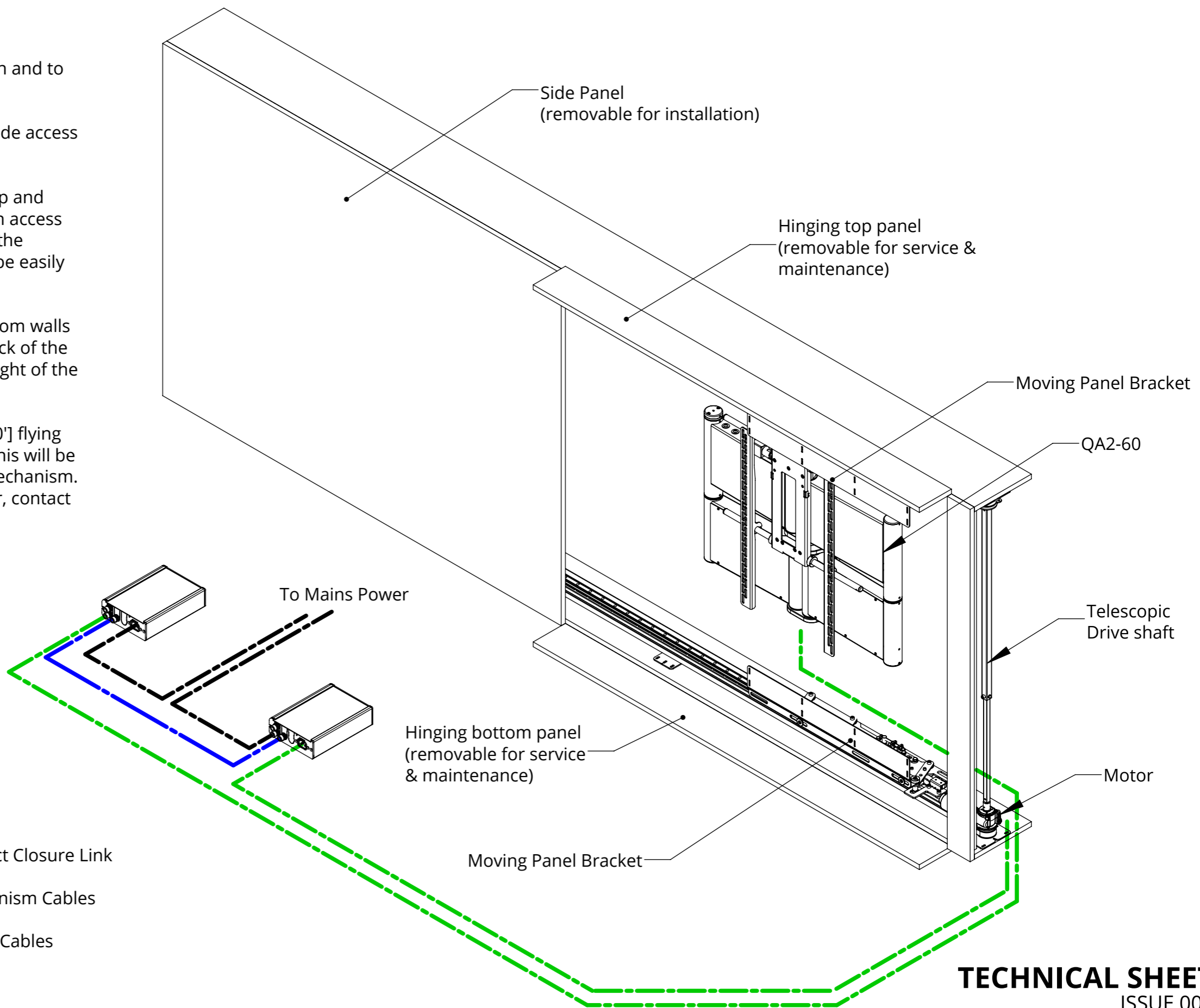

Control box wiring loom must be routed to the bottom right corner of the cabinet.

- - - - - Contact Closure Link
- - - - - Mechanism Cables
- - - - - Power Cables



# SPS-HZ-7 - QA2-60

## SLIDING PANEL MECHANISM - HORIZONTAL

### CONTROL BOX

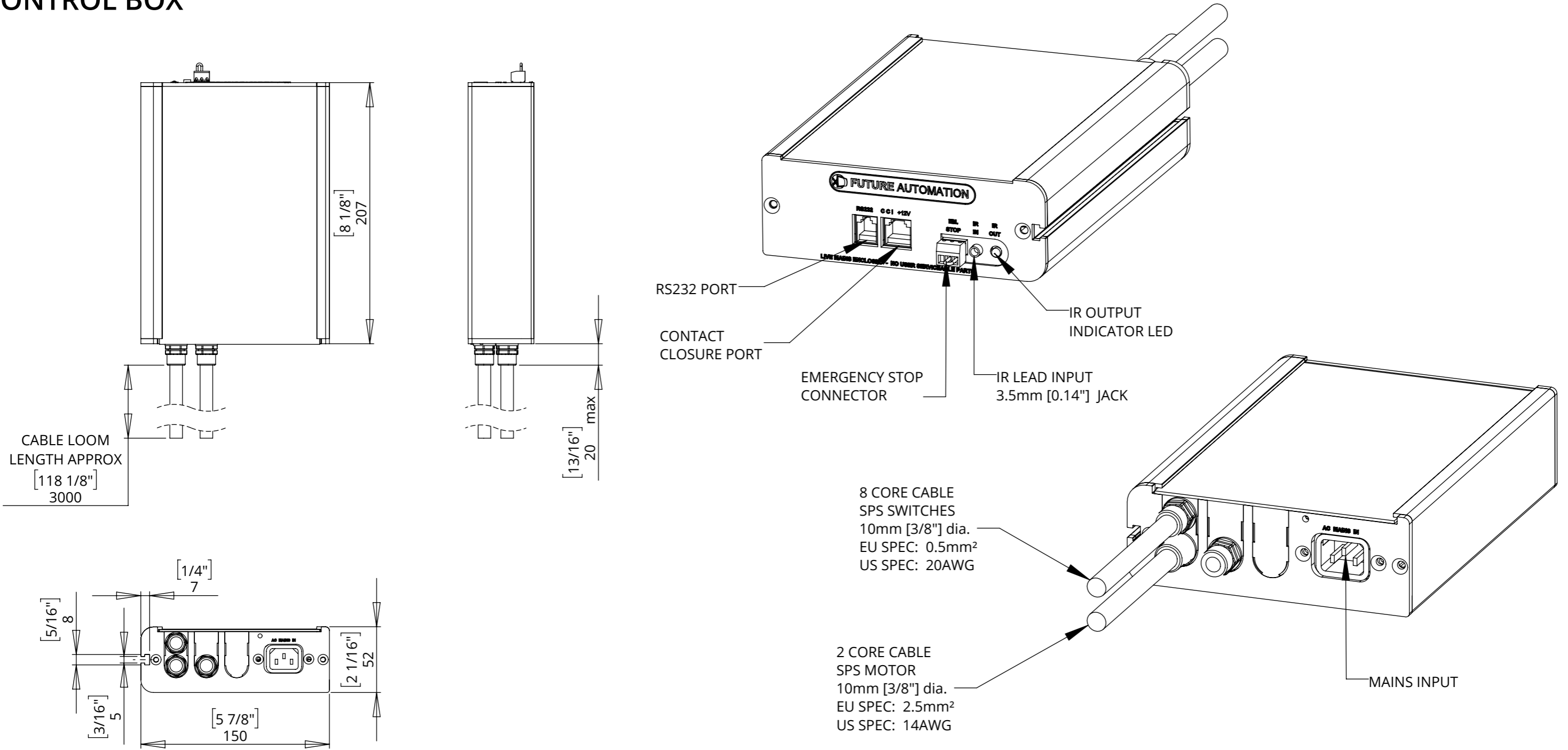

### NOTES

- POWER SUPPLY UNIT (PSU) WILL ALLOW 110V OR 240V AC INPUT. THE SAME PSU IS USED FOR EU OR US MAINS SUPPLIES.
- OTHER THAN CONTROL CABLES, ALL CABLES TERMINATE AT CONTROL BOARD VIA STANDARD PHOENIX CONNECTORS.
- CABLE LOOM LENGTH SUPPLIED AT APPROX. 3m [118"]. LOOM CAN BE EXTENDED UP TO MAXIMUM OF APPROX. 10m [400"].
- MINIMUM CABLE BEND RADIUS 25mm [1"].

# SPS-HZ-7 - QA2-60

## SLIDING PANEL MECHANISM - HORIZONTAL

### INSTALLATION OVERVIEW

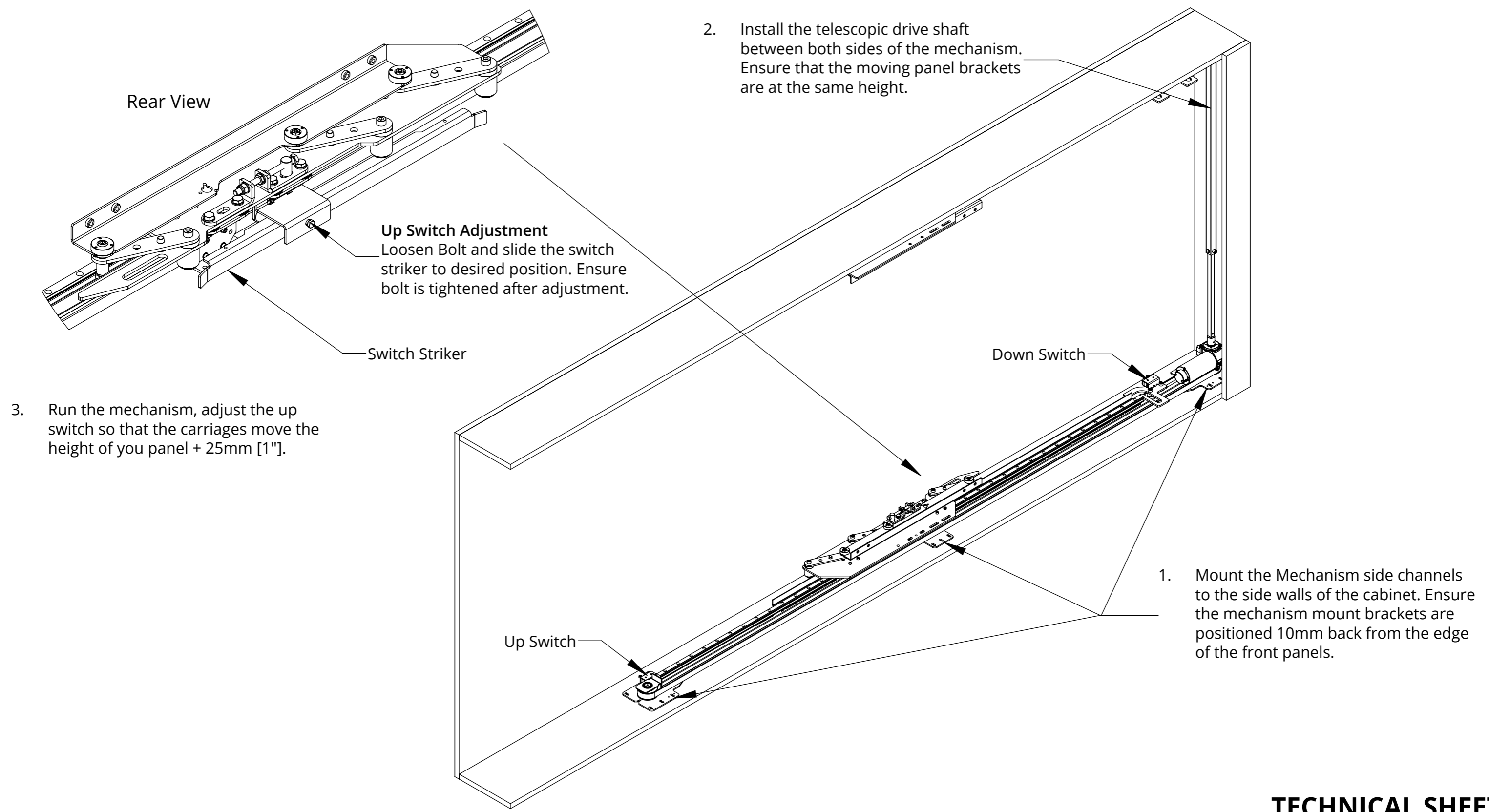

# SPS-HZ-7 - QA2-60

## SLIDING PANEL MECHANISM - HORIZONTAL

### INSTALLATION OVERVIEW

- 4. Mount the moving panel to the moving panel brackets 110mm from the base of the moving panel and 94mm in from the edge.
- 5. Mount the moving panel back onto the mechanism, use the slots in the mount brackets to align the panel and get it into the desired position.

