

SONANCE

INVISIBLE SERIES DATA SHEET

IS8T SPEAKER

TECHNICAL SPECIFICATIONS

SKU	40197
UOM	Each
Wave Flex Drive Unit	29in ² (188cm ²) bending wave diaphragm, 1.75" (44mm) voice coil
Air Flex Woofer	191in ² (1234cm ²) air pulse diaphragm, 8in (203mm) carbon fiber woofer
Frequency Response	40Hz-30kHz (+/- 3dB)
Nominal Impedance	4 Ohm
Power Handling (RMS)	160W
Sensitivity (2.83V/1m)	86dB
Working Temperature Range	0° - 125°F (-17.7° - 51.7°C)
Dispersion	170° hemispherical up to 10kHz
Transformer	60W with Sonance Laminated Core Technology
Transformer Taps	Primary Taps (70V): 7.5W, 15W, 30W, 60W; (100V): 15W, 30W, 60W; 4 Ohm Bypass
Overload Protection	Two Independent Self-Resetting Poly Switches, Safety Agency UL-1480A, UL-2043, CSA-C22.2 No.205, NFPA-70, and NFPA-90A
Product Dimensions (WxHxD)	16.10" x 24.13" x 3.86" (409mm x 613mm x 98mm)
Mounting Depth	3.39" (86mm)

DIMENSIONAL DRAWINGS

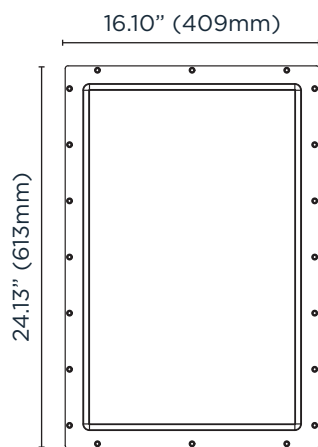

IS8T Back View

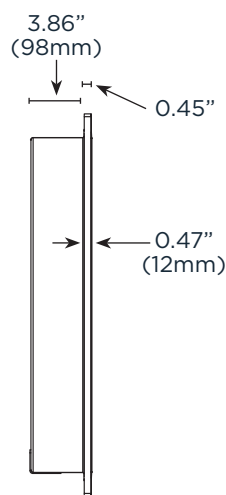

IS8T Side View

OPTIONAL ACCESSORIES

Preconstruction Zip Ring Bracket	93485
Space Saver	93493
DG-1 DISC System Depth Gauge	93491

ASSOCIATED PRODUCTS

INVISIBLE SERIES SPEAKERS

IS10 Speaker	93480
IS8 Speaker	93479
IS6 Speaker	93478
IS6T Speaker	40198

INVISIBLE SERIES WOOFER

IS15W Woofer	93482
--------------	-------

LIMITED FIFTEEN (15) YEAR WARRANTY

Sonance warrants to the first end-user purchaser that this Sonance-brand product ("Product"), when purchased from an authorized Sonance Dealer/Distributor, will be free from defective workmanship and materials for the period stated above. Sonance will at its option and expense during the warranty period, either repair the defect or replace the Product with a new or remanufactured Product or a reasonable equivalent. For more details please refer to the product manual.

©2021 Sonance. All rights reserved. Sonance is a registered trademarks of Dana Innovations. Due to continuous product improvement, all features and specifications are subject to change without notice. For the latest Sonance product specification information visit our website at www.sonance.com.

SONANCE • 991 Calle Amanecer • San Clemente, CA 92673 USA • Phone: (949) 492-7777 • Fax: (949) 361-5151 • Technical Support: (949) 492-7777 • www.sonance.com • 06.08.2021